



Tools for  
Science  
& Medicine

VICI Metronics Inc.

## Dynacalibrator® Portable Calibration Gas Generator

- Low PPB to high PPM range
- Temperature control to 100°C
- Internal 4 LPM pump
- Rechargeable 8 hour battery



### Description

VICI Metronics Dynacalibrators enable calibrations traceable to NIST standards for almost any gas analyzer, in the lab or in the field. They are ideal for verifying the accuracy of analytical data from air pollution monitoring, industrial hygiene surveys, odor survey programs, and other instruments measuring gas concentration.

The design takes full advantage of all the conveniences inherent in our Dynacal® permeation devices to generate and deliver precise concentrations ranging from ppb to high ppm for hundreds of different compounds. The portable Model 120 features a glass or PTFE permeation chamber with screw cap access, solid state proportional temperature controller with digital readout of set point and chamber temperature, heater switch with LED indicator, flowmeter and flow control valve, span and overflow outlets, 12 VDC internal pump, activated charcoal scrubber, and molded fiberglass case.

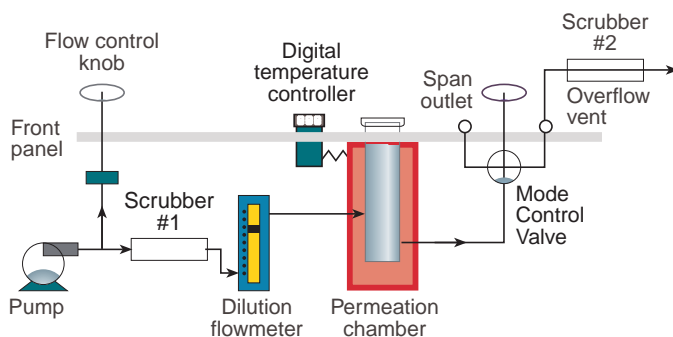

### Advantages Over Bottled Standards

Calibration devices from VICI Metronics offer several key advantages over cylinder-supplied gas calibration standards.

Economy is always a major consideration; customers who have done the arithmetic, factoring in the cost of cylinder purchase, shipment, and disposal, typically discover that the purchase of a Dynacalibrator and a supply of permeation devices will start to save them money in the second year of use.



Multicomponent mixtures can be easily generated with a Dynacalibrator and the appropriate combination of permeation devices. This technique also allows the removal of a single component from a gas mixture by simply removing the appropriate permeation device. Alternative methods require expensive custom mixtures or a large number of gas cylinders, which consume valuable lab space as well.

Bottled standards can also have problems arising from degradation of the standard within the cylinder, from changes in the concentration levels as the cylinder pressure changes, and from interaction of calibration components and surfaces.

## Specifications

---

Panel features .....	Permeation chamber access (screw cap) Digital readout for chamber temperature Flowmeter with flow control valve Span and overflow outlet (1/4" tube fitting) Power switch with LED indicator light Power receptacle for 110 VAC operation and recharging Solid state proportional temperature controller Digital readout for set point and chamber temperature PTFE mode select valve – Standby or Span Heater switch with LED indicator light
Permeation chamber .....	Glass: 0.85" ID x 7.75" (2.1 cm x 19.7 cm) PTFE: 0.69" ID x 7.75" (1.7 cm x 19.7 cm)
Temperature range .....	5°C above ambient to 100°C Solid state proportional temperature controller
Flowmeters .....	Precision graduated rotometers Model 120-1 1.0 L/min Model 120-2 2.4 L/min Model 120-4 4.0 L/min
Pump .....	Internal Pump (12 VDC) Single head 2.4 L/min Dual head 4.0 L/min
Scrubbers .....	Activated charcoal
Power Supply .....	Internal rechargeable gel-type battery (12V) with up to 24 hour capacity
Accessories .....	Power cord for 110 VAC operation and recharging Adapter for 12V vehicle system Forceps for device insertion and removal
Case .....	Molded fiberglass with handle for field use 10.5" wide x 9.5" deep x 13" high (27 cm x 24 cm x 33 cm)
Instrument weight .....	24 lbs. (11 kg)