



Tools for
Science
& Medicine

Dynacalibrator® Model 500 Calibration Gas Generator

- PPB to high PPM range
- Switchable carrier flow – dilution or vent
- CE certified
- Two separate permeation chambers with independent temperature control



Description

VICI Metronics Dynacalibrators enable calibrations traceable to NIST standards for almost any gas analyzer, in the lab or in the field. They are ideal for verifying the accuracy of analytical data from air pollution monitoring, industrial hygiene surveys, odor survey programs, and other instruments measuring gas concentration.

The design takes full advantage of all the conveniences inherent in our Dynacal® permeation devices to generate and deliver precise concentrations ranging from ppb to high ppm for hundreds of different compounds. The innovative Model 500 features two separate permeation chambers with independent temperature control systems. The chambers can be used independently, or together to combine concentrations of trace components. Separate solenoid valves allow the carrier flows to be switched from the dilution flow to a vent port.

Advantages Over Bottled Standards

Calibration devices from VICI Metronics offer several key advantages over cylinder-supplied gas calibration standards.

Economy is always a major consideration; customers who have done the arithmetic, factoring in the cost of cylinder purchase, shipment, and disposal, typically discover that the purchase of a Dynacalibrator and a supply of permeation devices will start to save them money in the second year of use.



Multicomponent mixtures can be easily generated with a Dynacalibrator and the appropriate combination of permeation devices. This technique also allows the removal of a single component from a gas mixture by simply removing the appropriate permeation device. Alternative methods require expensive custom mixtures or a large number of gas cylinders, which consume valuable lab space as well.

Bottled standards can also have problems arising from degradation of the standard within the cylinder, from changes in the concentration levels as the cylinder pressure changes, and from interaction of calibration components and surfaces.

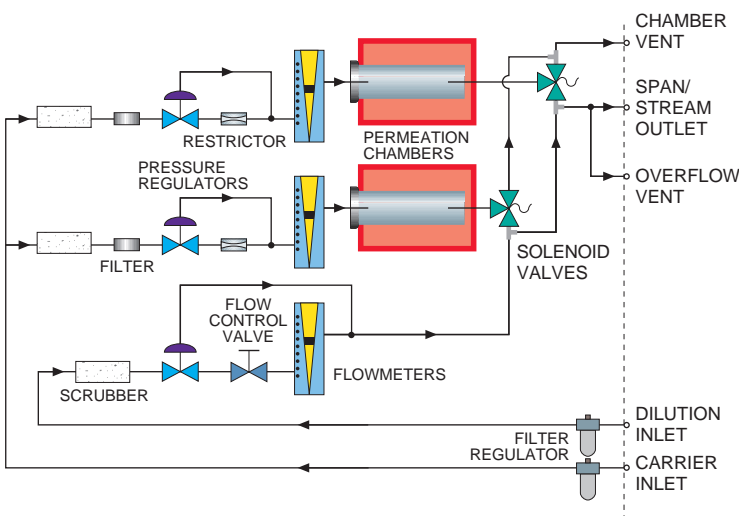

Specifications

Front panel features	Wide-neck Pyrex® chambers for easy access Digital thermometer (0-110°C) for precise chamber temperature readout Long-life LED indicators
Permeation chamber	Pyrex® (standard) .85" ID x 9.4" (2.1 cm x 24 cm) PTFE (Option P) .69" ID x 9.4" (1.8 cm x 24 cm) Stainless steel (Option H) .875" ID x 9.25" (2.2 cm x 23.5 cm)
Permeation device	
Maximum total length	23.5 cm (9.25")
Maximum diameter	1.6 cm (0.62")
Temperature controller	Solid state proportional with 0.1°C set point accuracy, NIST traceable, and stability of ±0.01°C
Temperature control range	Standard unit: 2°C above ambient to 50°C Expanded temperature unit: 2°C above ambient to 110°C
Output pressure	0 - 5 psi standard; 50 psi optional (Option H)
Flowmeters	High resolution 15 cm graduated scale. Certified ±1% accuracy full scale (1% at maximum flow, 3% at minimum flow, NIST traceable. Full scale ranges of 1, 2, 5, 10, 15, and 20 L/min.
Dimensions	17" wide x 23.75" deep x 10.5" high (43.2 cm x 60.3 cm x 26.7 cm)
Chamber temperature equilibrium time	Less than 1 hour
External gas stream supply and modification	Separate inlets for connecting external gas supply for carrier and dilution streams
Weight	74 lbs. (33.3 kg)
Accessories	Power cord for 110 VAC power source (220 VAC w/option C) Forceps for removing and inserting permeation devices Reference manual
Options	Option C 220 VAC Option H High pressure stainless steel chamber Option T Expanded temperature range